

Service Schematics

NOKIA

6600 SLIDE

RM-414

Introduction

IMPORTANT:

This document is intended for use by authorized NOKIA service centers only.

“Service Schematics” was created with focus on customer care.
The purpose of this document is to provide further technical repair information for NOKIA mobile phones on Level 3/4 service activities.
It contains additional information such as e.g. “Component finder”.

Saving process time and improving the repair quality is the aim of this document.
It is to be used additionally to the service manual and other training or service information such as Service Bulletins.

While every endeavour has been made to ensure the accuracy of this document, some errors may exist. If the reader finds any errors, NOKIA shall be notified in writing.

Please send E-Mail to: TrainingAndVendor.Development@nokia.com

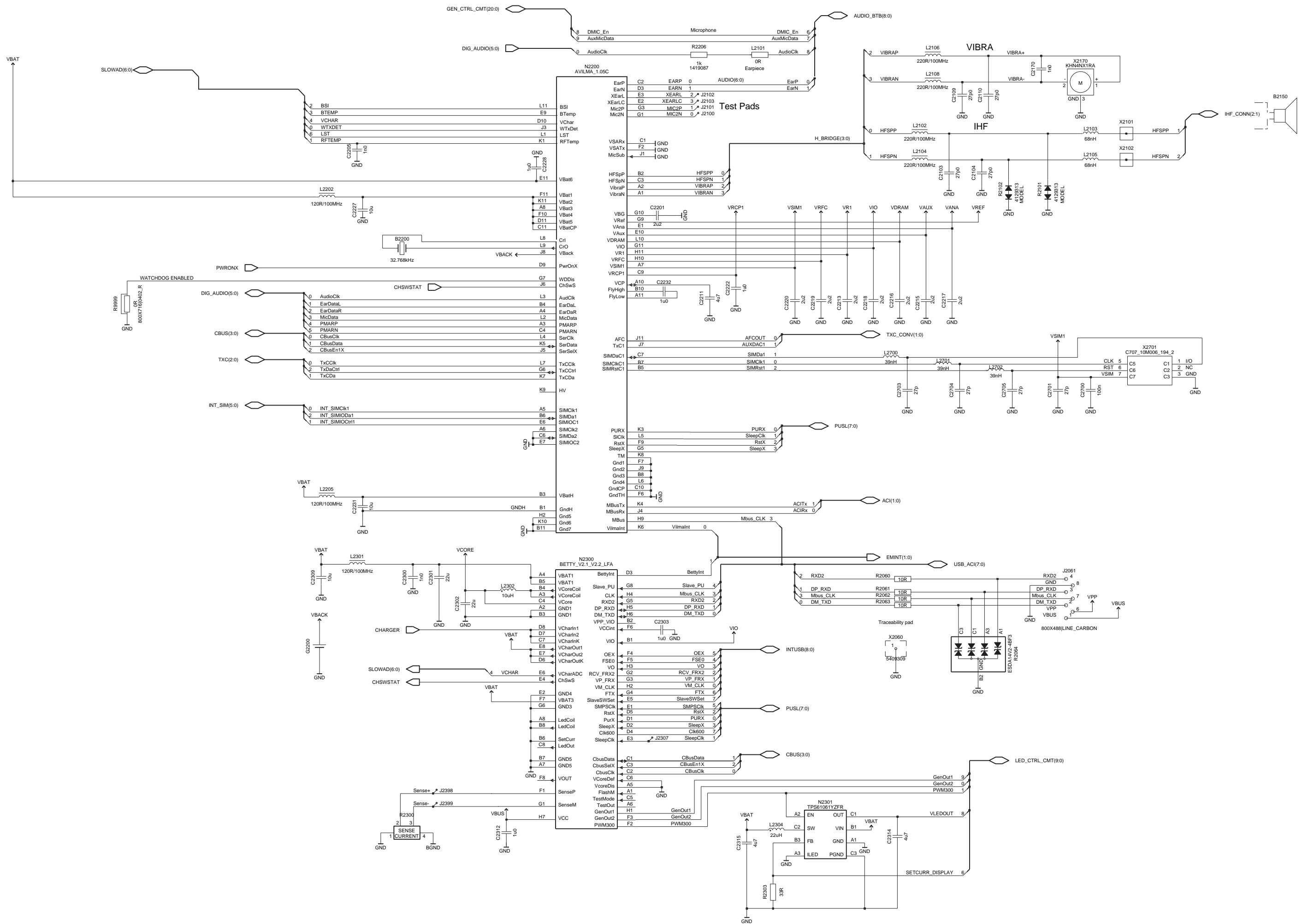

Table of Content

Front page	1
AVilma, Betty	2
RAP	3
Camera Interface	4
USB OTG and Charging Interface	5
Main board to top flex interface	6
RF part	7
Component finder	8

Copyright © NOKIA

This material, including documentation and any related computer programs is protected by copyright, controlled by NOKIA. All rights are reserved. Copying, including reproducing, modifying, storing, adapting or translating any or all of this material requires the prior written consent of NOKIA. This material also contains company confidential information, which may not be disclosed to others without the prior written consent of NOKIA.



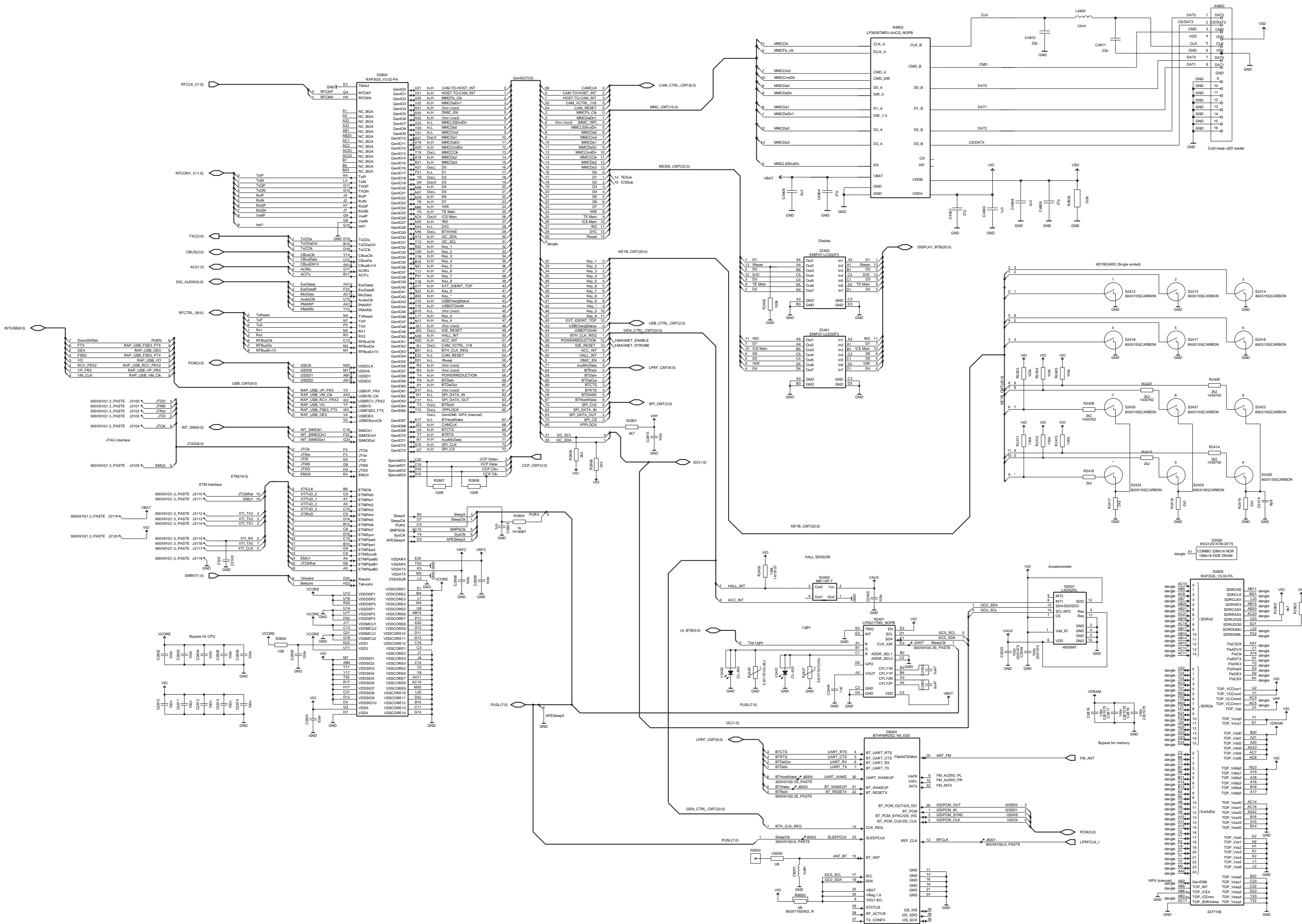

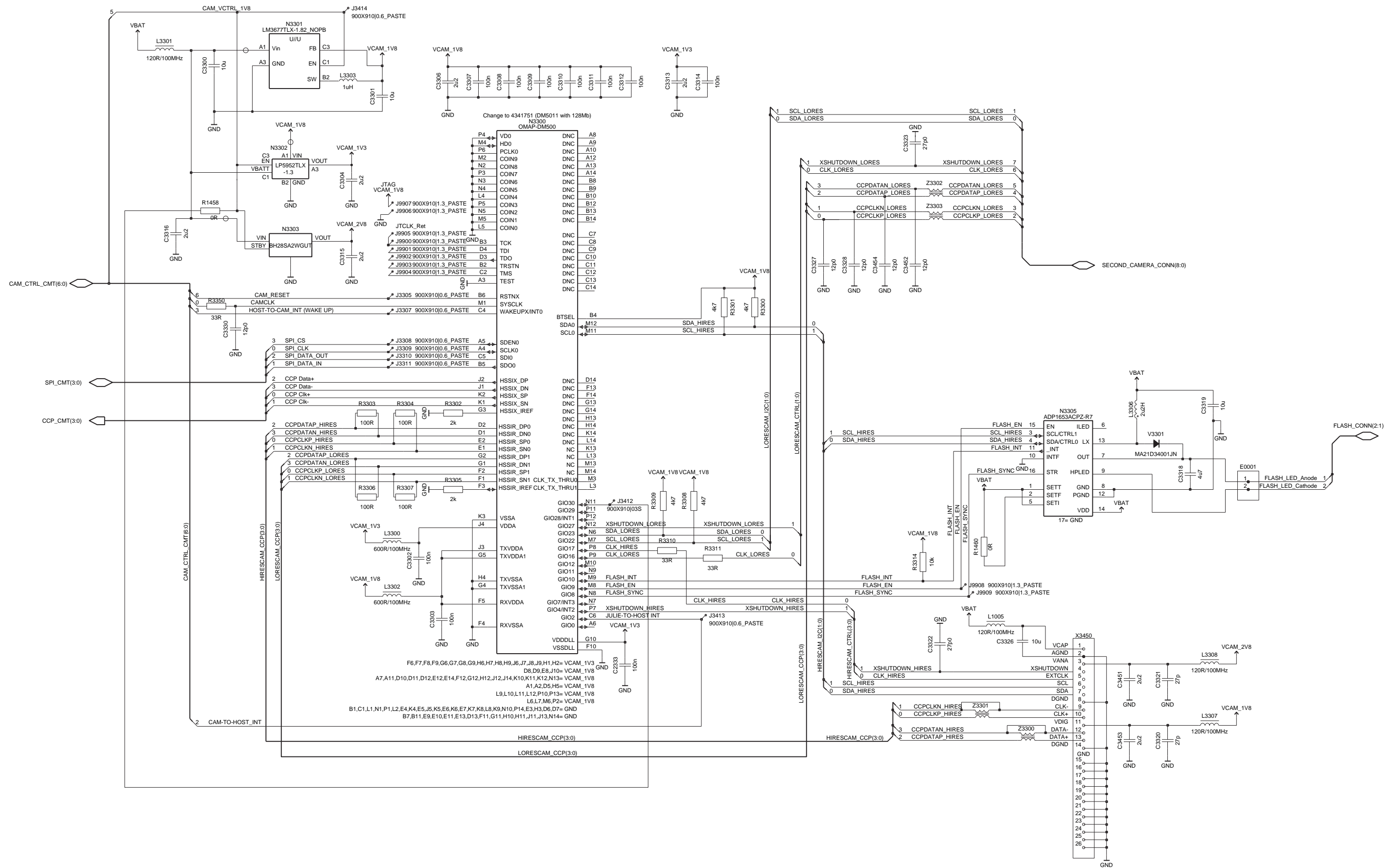

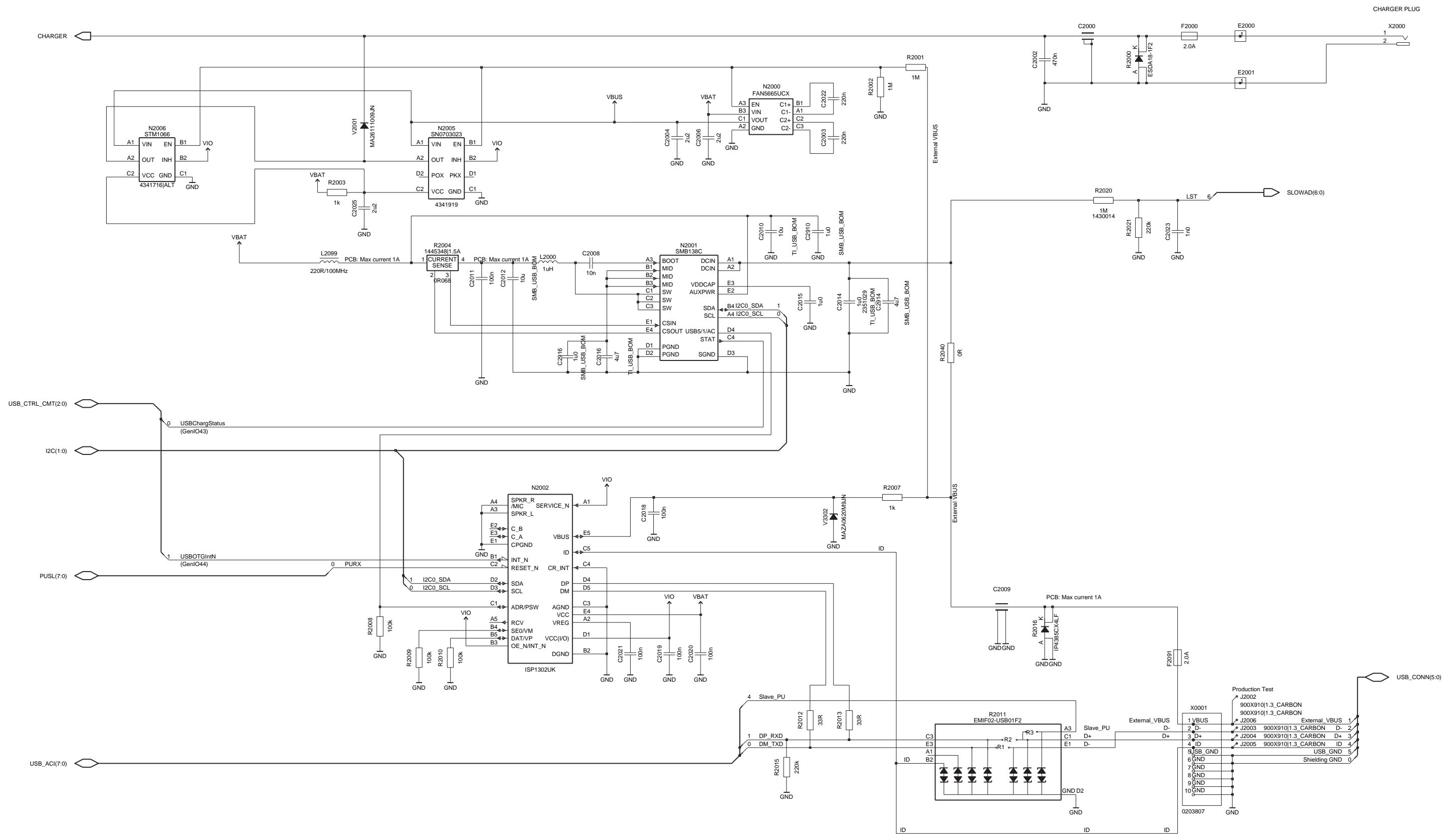

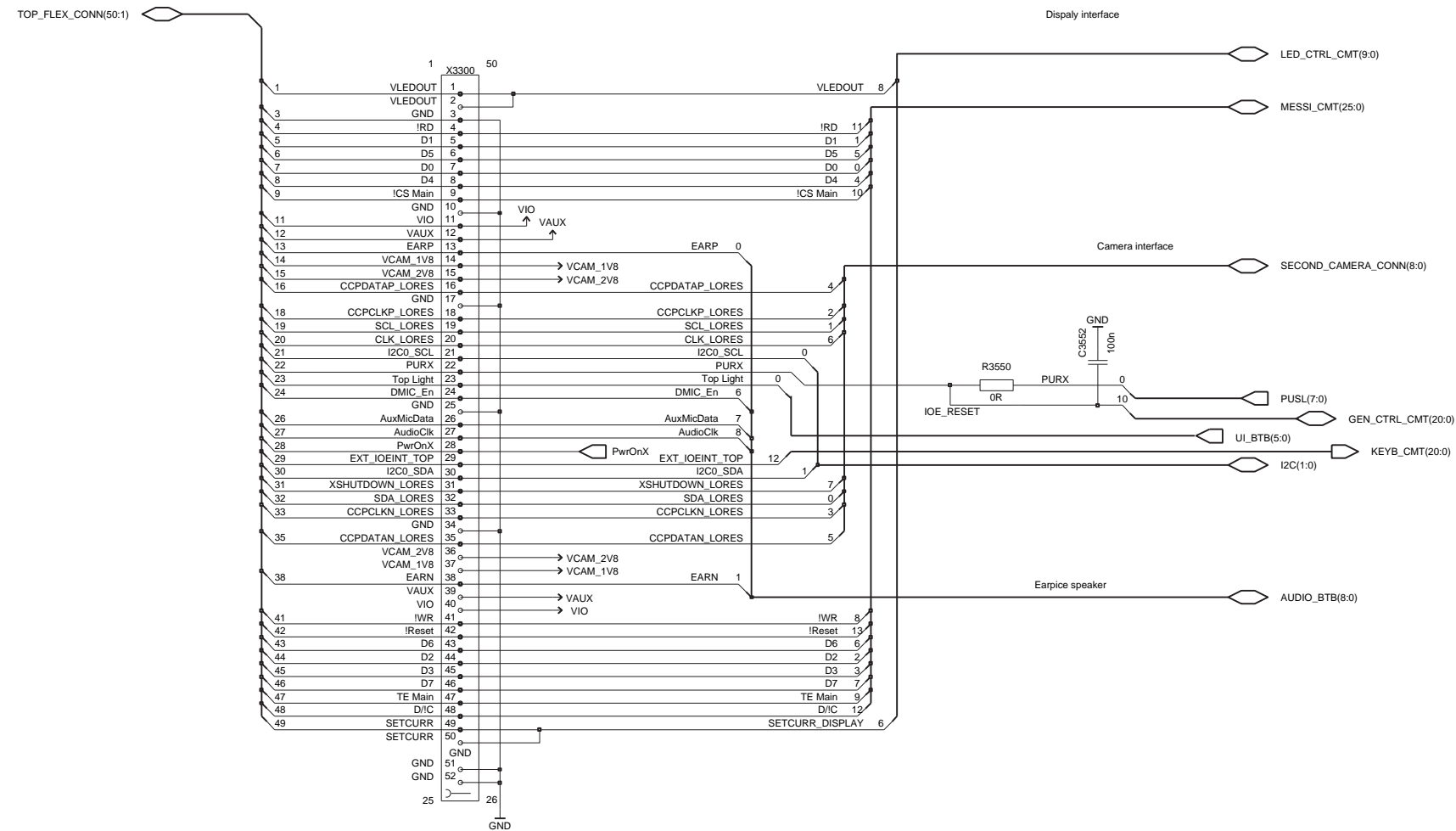

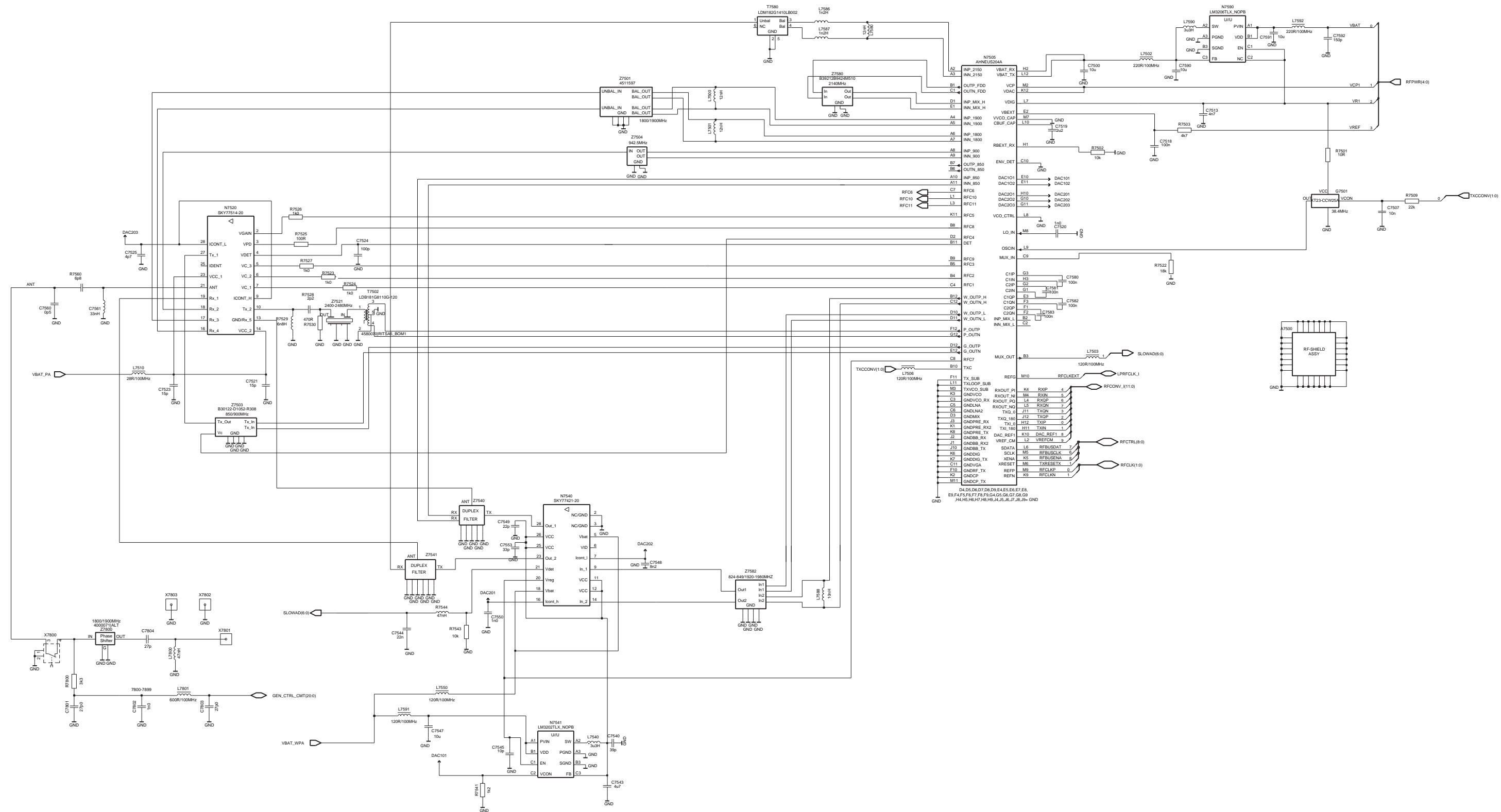

A	C2302	H2	C3309	E5	C7550	J9	J3110	I4	L2302	I2	N7590	K4	R2421	O1	X		
A2000	G5	C2303	G2	C3310	F7	C7553	K7	J3111	I4	L2304	G9	R	R2800	F4	X0001	B7	
A7500	K5	C2309	G2	C3311	G7	C7561	J7	J3112	J4	L2700	O4	R1458	E5	R2801	I4	X2011	N5
B	C2312	G2	C3312	F7	C7580	J2	J3113	K4	L2701	N4	R1460	H9	R2802	F4	X2012	D7	
B2200	H5	C2314	G9	C3313	F5	C7581	J2	J3114	K4	L2702	N4	R2000	F1	R2803	F3	X2013	O1
C	C2315	F9	C3314	F5	C7582	J2	J3115	K4	L3300	F5	R2001	H8	R2804	I3	X2014	N1	
C2000	F2	C2333	F7	C3315	E5	C7583	J2	J3116	K4	L3301	F4	R2002	H8	R2805	G5	X2015	O9
C2002	G2	C2402	G7	C3316	E4	C7590	L4	J3117	J4	L3302	E6	R2003	G7	R2806	G5	X2016	M5
C2003	H8	C2403	H7	C3318	I8	C7591	K4	J3118	G4	L3303	E5	R2007	E7	R2807	F3	X2060	N1
C2004	G7	C2404	G7	C3319	I8	C7592	K5	J3119	J4	L3306	I9	R2008	E7	R2808	F3	X2070	P7
C2006	G8	C2405	K3	C3320	D2	C7801	M5	J3120	H4	L3307	D3	R2009	F8	R3300	G7	X2101	R7
C2008	F7	C2419	P3	C3321	D4	C7802	F4	J3305	F3	L3308	D4	R2010	E8	R3301	G6	X2102	O7
C2009	D8	C2503	D4	C3322	D4	C7803	F3	J3307	F5	L4800	N7	R2011	D6	R3302	F5	X2170	C6
C2011	G8	C2504	D3	C3323	F7	C7804	O5	J3308	G6	L7500	J4	R2012	D7	R3303	E5	X2701	O3
C2012	F8	C2700	N2	C3326	D5	D	J3309	E6	L7501	J4	R2013	D7	R3304	E5	X3300	D9	
C2015	F8	C2701	M2	C3327	D5	D2800	H4	J3310	F6	L7502	I4	R2015	D7	R3305	F5	X3450	B4
C2018	E8	C2703	O4	C3328	D5	D3000	H4	J3311	G6	L7503	J3	R2016	D8	R3306	F5	X4800	N7
C2019	E7	C2704	N4	C3330	F4	D6000	E3	J3412	G6	L7506	L3	R2020	G5	R3307	F5	X6000	O1
C2020	E8	C2705	N4	C3451	D4	E	J3413	E6	L7510	L6	R2021	G5	R3308	G6	X7800	M5	
C2021	E7	C2800	F4	C3452	E6	E0001	B5	J3414	I5	L7540	J7	R2040	F7	R3309	G6	X7801	P5
C2022	H8	C2801	I4	C3453	D2	E2000	C1	J6000	E2	L7550	J9	R2060	M4	R3310	G6	X7802	P5
C2023	G5	C2802	G2	C3454	E6	E2001	C1	J6001	E2	L7586	J4	R2061	N4	R3311	G6	X7803	P6
C2025	G7	C2803	I4	C3552	E7	F	J6002	F2	L7587	J4	R2062	N4	R3314	F7	Z		
C2070	N9	C2804	F4	C4800	N7	F2000	D1	J6003	E2	L7588	K3	R2063	N4	R3350	F3	Z2400	D6
C2071	L8	C2805	G5	C4801	N7	F2091	A8	J7500	K2	L7590	L4	R2064	N4	R3550	D7	Z2401	E6
C2072	O7	C2806	I3	C4804	M7	G	J7501	K2	L7591	J8	R2070	O7	R4805	M7	Z3302	D6	
C2073	O8	C2808	I4	C4806	M7	G2200	F4	J9900	C4	L7592	K4	R2071	O8	R7501	K2	Z3303	D5
C2074	L8	C2809	F3	C4808	M7	G7501	I2	J9901	C4	L7800	P5	R2101	P9	R7502	J3	Z7501	J4
C2103	H7	C2810	I3	C4809	M7	J	J9902	C4	L7801	F3	R2102	P8	R7503	J3	Z7503	K4	
C2104	H7	C2811	G2	C4810	N7	J2002	B7	J9903	B4	N	R2206	G5	R7509	K3	Z7504	K4	
C2109	G7	C2812	F4	C4811	N7	J2003	A7	J9904	C4	N2000	H8	R2300	O7	R7523	J6	Z7521	L5
C2110	G7	C2813	G5	C6000	P2	J2004	B7	J9905	D4	N2001	F8	R2303	G8	R7524	J6	Z7540	K7
C2170	D5	C2814	I5	C6001	P2	J2005	A7	J9906	B4	N2002	E8	R2400	I6	R7525	J5	Z7541	K7
C2201	I6	C2815	I5	C7500	K2	J2006	B7	J9907	C4	N2006	G7	R2402	D6	R7526	J5	Z7580	J4
C2205	G5	C2816	F5	C7507	K3	J2051	M3	J9908	H9	N2200	H6	R2403	O6	R7527	J5	Z7582	I3
C2211	I7	C2817	I5	C7513	J2	J2073	M3	J9909	H9	N2300	H2	R2404	P5	R7528	L6	Z7800	O5
C2213	I6	C2818	G2	C7518	J3	J2100	M2	L	N2301	G8	R2405	P3	R7541	J9			
C2215	I6	C2823	I3	C7519	J2	J2101	M3	L1005	D5	N2400	J3	R2406	P3	R7543	J8		
C2216	I5	C2910	F8	C7520	J2	J2102	M4	L2000	G8	N2401	H7	R2407	P5	R7544	J8		
C2217	G6	C2914	F7	C7521	J6	J2103	M3	L2099	F8	N2501	D3	R2408	O6	R7560	J7		
C2218	I6	C2916	F7	C7523	L6	J2307	I2	L2101	E3	N3300	F6	R2411	O6	R7800	M5		
C2219	I5	C3100	I3	C7524	J5	J2398	G3	L2102	G7	N3301	F4	R2412	P4	T			
C2220	H7	C3300	F4	C7525	J5	J2399	G3	L2103	P9	N3302	F4	R2413	P2	T7502	I5		
C2222	I6	C3301	F5	C7540	J7	J2407	H7	L2104	H7	N3303	E5	R2414	P2	T7580	J4		
C2227	I6	C3302	F5	C7543	J7	J3100	H4	L2105	P8	N3305	H9	R2415	P4	V			
C2228	I6	C3303	E6	C7544	J8	J3101	H4	L2106	G7	N4802	N7	R2416	O6	V2001	F2		
C2231	G6	C3304	F4	C7545	J8	J3102	H4	L2108	G7	N7505	J3	R2417	O6	V2400	O9		
C2232	I7	C3306	G5	C7547	J8	J3103	H4	L2202	I6	N7520	K6	R2418	P4	V2401	O1		
C2300	H2	C3307	E6	C7548	J9	J3104	I4	L2205	G6	N7540	K8	R2419	P3	V3301	H8		
C2301	H2	C3308	G6	C7549	K7	J3105	I4	L2301	G2	N7541	J8	R2420	O9	V3302	E8		

